

Art. Nr. 109160, 161612  
185755, 194640

LKZ 40605

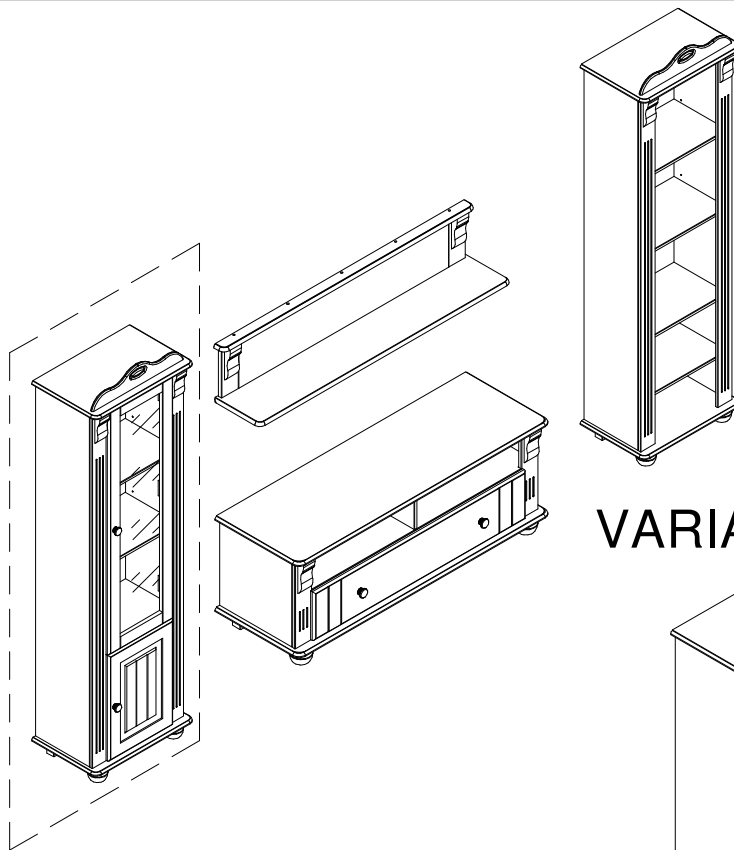

VARIANT 1    VARIANT 2

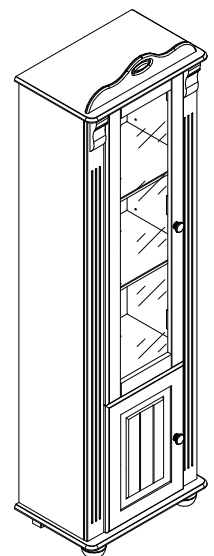
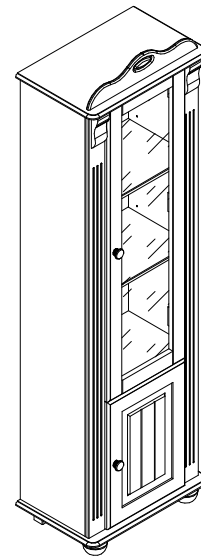

- |           |                                    |           |                                |
|-----------|------------------------------------|-----------|--------------------------------|
| <b>D</b>  | <b>Montageanleitung</b>            | <b>GB</b> | <b>Assembly instructions</b>   |
| <b>FR</b> | <b>Notice de montage</b>           | <b>IT</b> | <b>Istruzioni di montaggio</b> |
| <b>NL</b> | <b>Handleiding voor de montage</b> | <b>PL</b> | <b>Instrukcja montażu</b>      |
| <b>CZ</b> | <b>Montážní návod</b>              | <b>SK</b> | <b>Návod na montáž</b>         |
| <b>HU</b> | <b>Szerelési útmutató</b>          | <b>RO</b> | <b>Instrukțiuni de montaj</b>  |
| <b>TR</b> | <b>Montaj talimatı</b>             | <b>RU</b> | <b>Инструкция по монтажу</b>   |

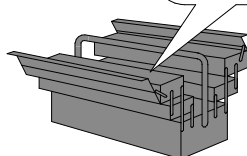
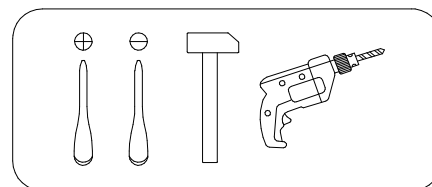
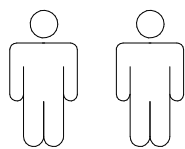

0  
10  
20  
30  
40  
50  
60  
70  
80  
90  
100  
110  
120  
130  
140  
150  
160  
170  
180  
190  
200

Service · Dienstverlening · Serwis · Servis · Сервисная служба

Name · Naam · Nazwa · Isim · Название	
Nr. · No. · Номер	
Typ · Type · Tip · Тип	

- |                      |                        |                            |                       |                       |
|----------------------|------------------------|----------------------------|-----------------------|-----------------------|
| <b>A</b> 8x30<br>x17 | <b>B</b> 15x9.5<br>x24 | <b>C</b> 7x24(8mm.)<br>x24 | <b>D</b> 7x50<br>x6   | <b>E</b> x5           |
| <b>F</b> x2          | <b>G</b> x5            | <b>H</b> 3.5x15<br>x19     | <b>I</b> 3.5x30<br>x4 | <b>J</b> 3.5x35<br>x2 |
| <b>K</b> x1          | <b>L</b> x4            | <b>M</b> x4                | <b>N</b> x25          | <b>O</b> x4           |
| <b>P</b> x1          | <b>Q</b> 4,0x60<br>x10 | <b>R</b> 3.0x12<br>x4      | <b>S</b> x12          |                       |

N	Size/MaB (mm)	Qty	✓	N	Size/MaB (mm)	Qty	✓
1	540x350x14	1		9	468x288x14	3	
2	540x350x14	1		10	1682x488x3,2	1	
3	1664x295x14	1		11	72x66x45	5	
4	1664x295x14	1		12	54x140x28	2	
5	470x304x14	1		13	60x40x40	2	
6	1664x80x14	1		14	80x80x60	2	
7	1664x80x14	1		15	498x350x18	1	
8	496x98x14	1		16	1160x350x18	1	

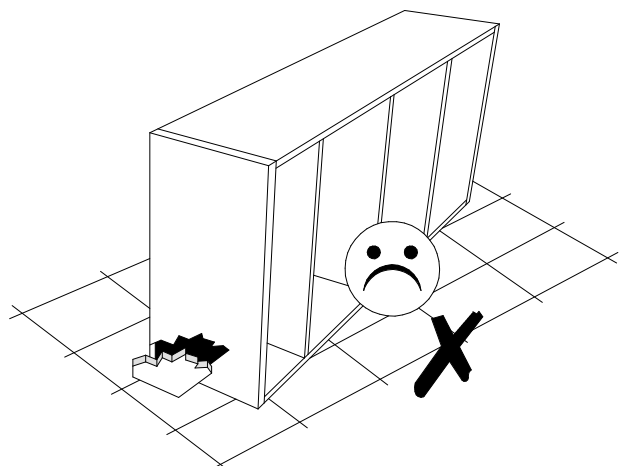
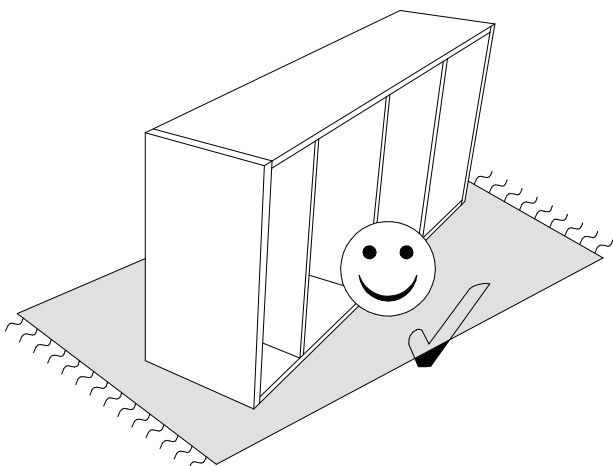
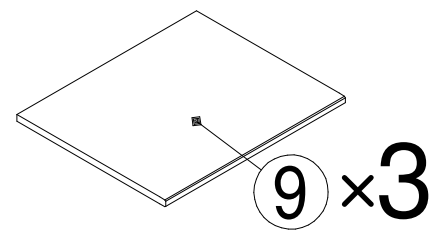
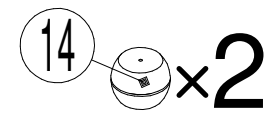
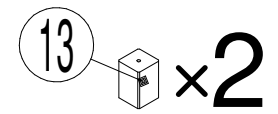
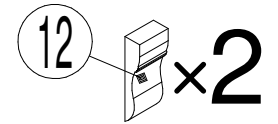
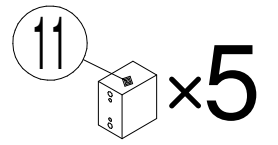
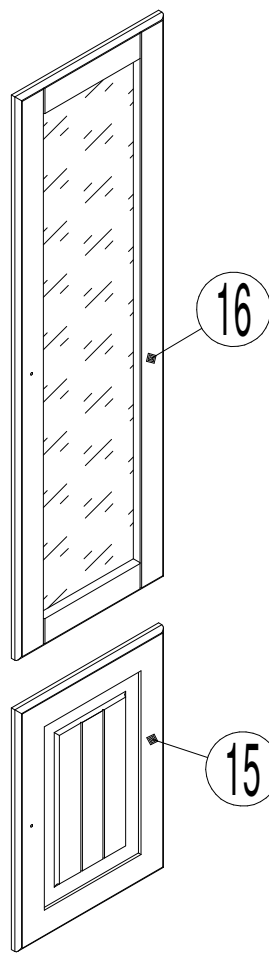
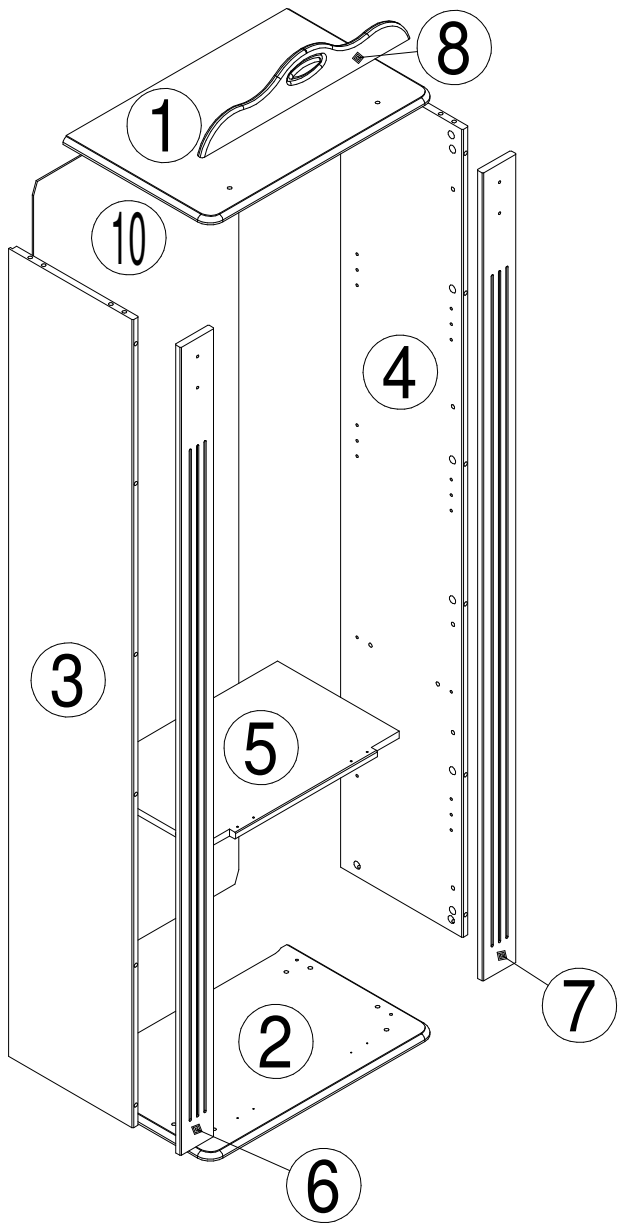

1

VARIANT 1

VARIANT 2

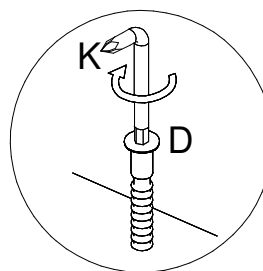
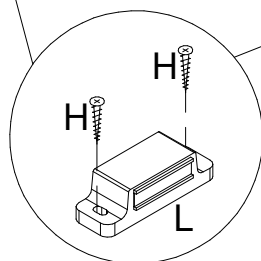
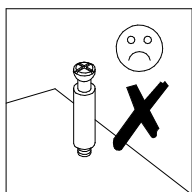
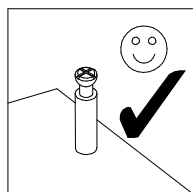
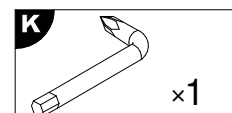
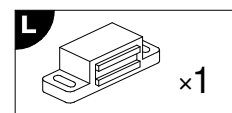
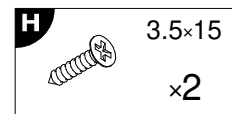
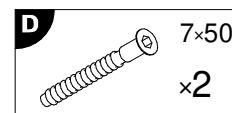
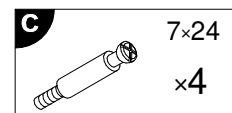
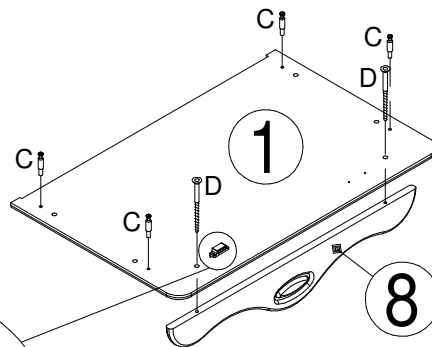
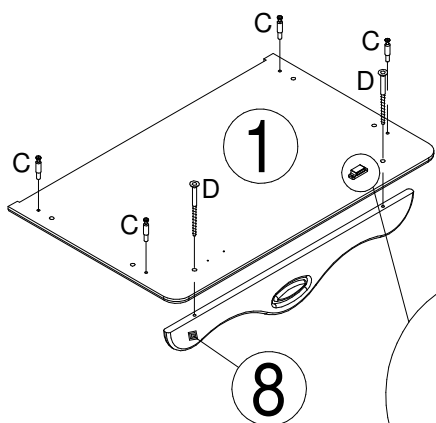

2

VARIANT 1

VARIANT 2

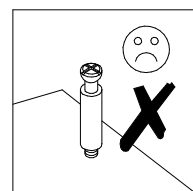
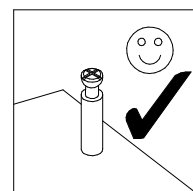
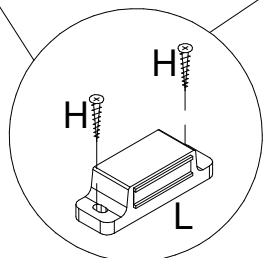
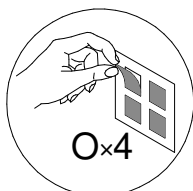
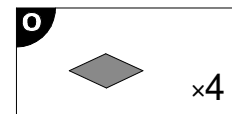
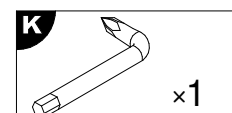
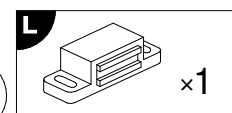
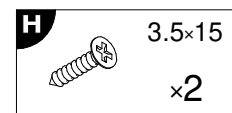
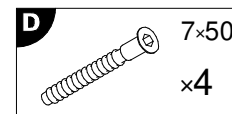
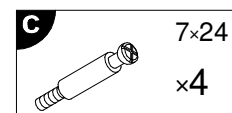
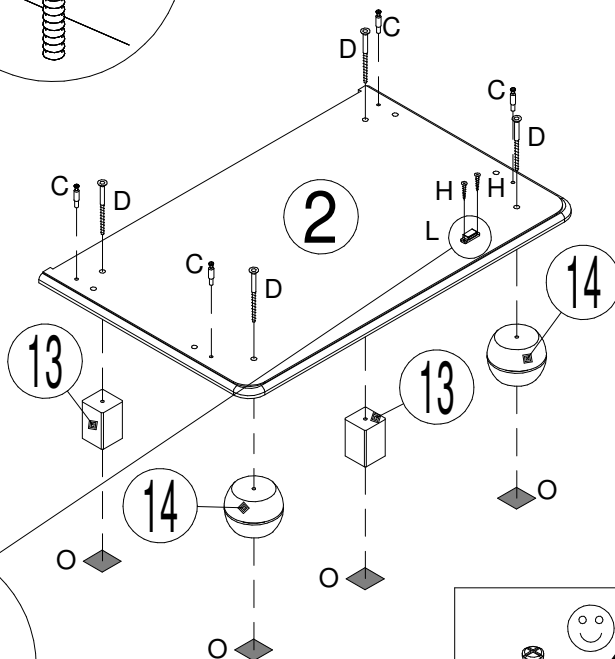
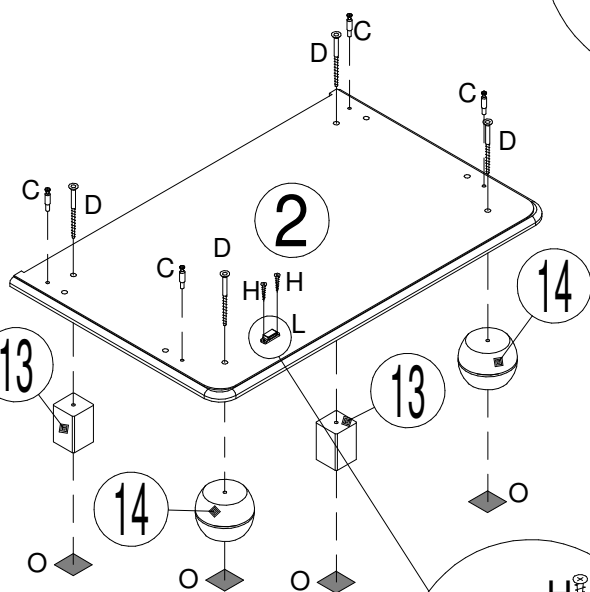

VARIANT 1

VARIANT 2

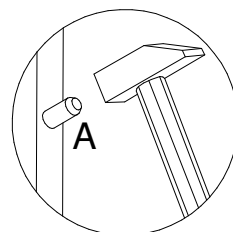
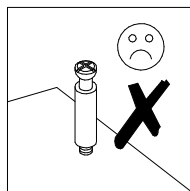
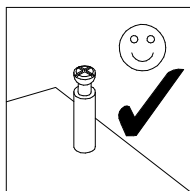
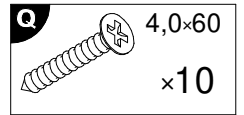
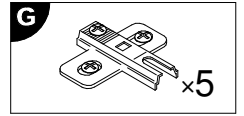
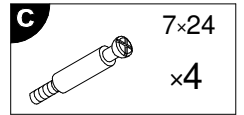
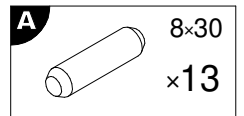
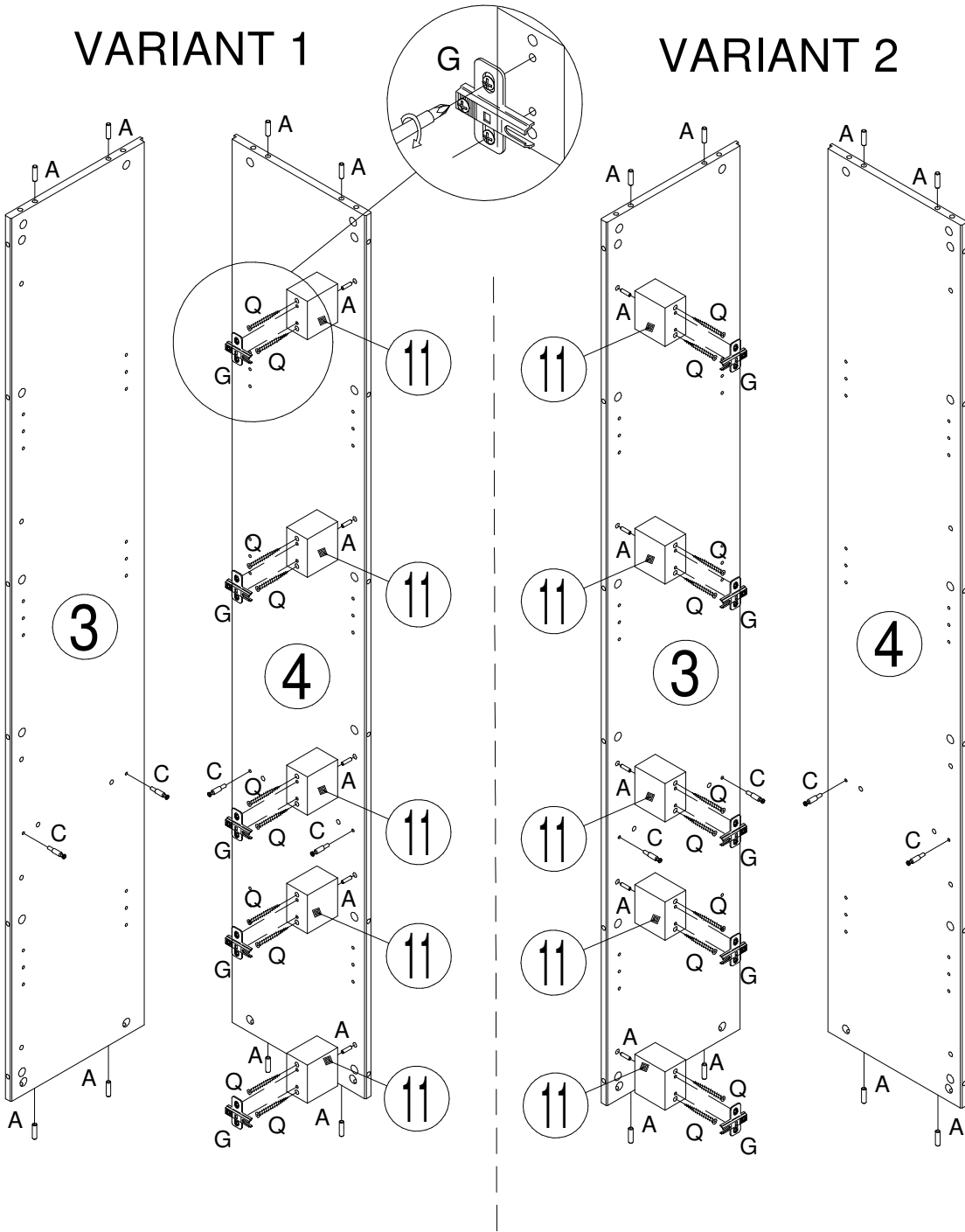

4

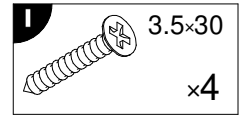
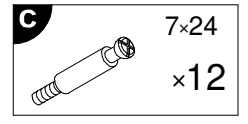
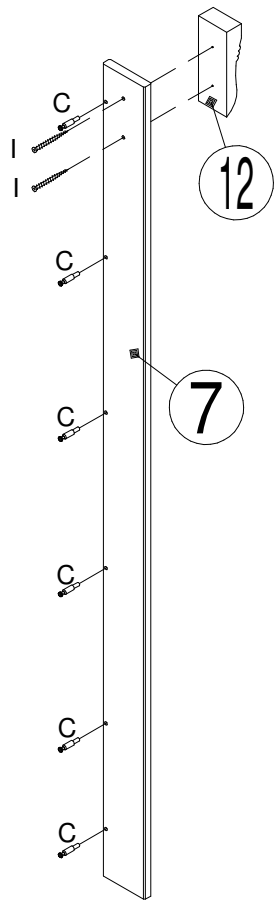
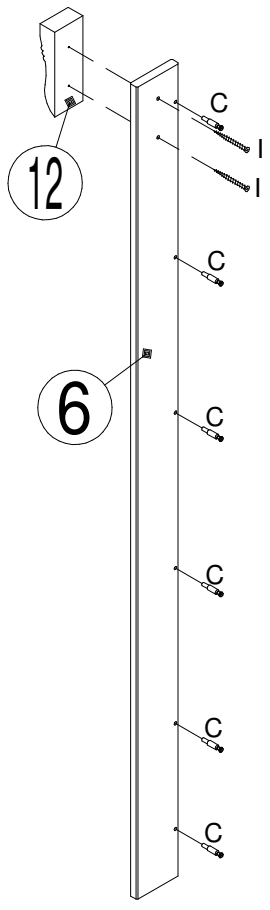

5

VARIANT 1

VARIANT 2

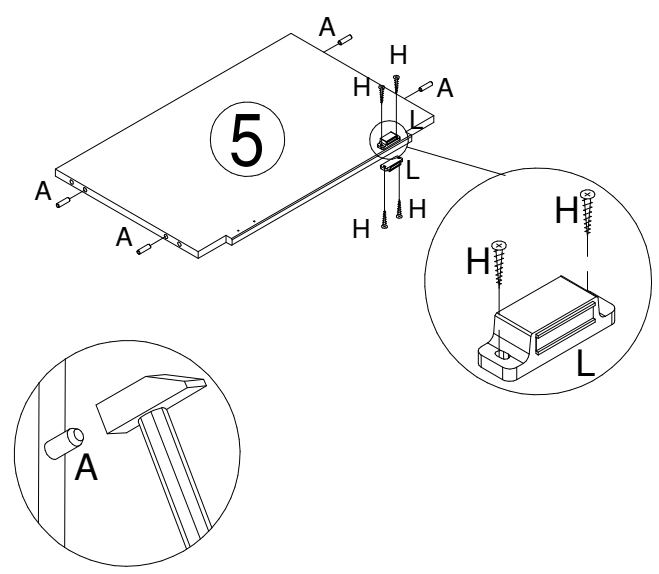
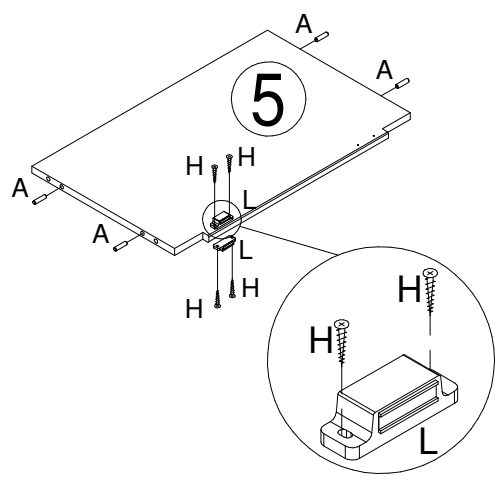
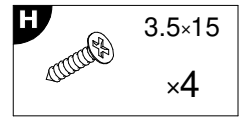
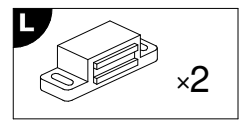
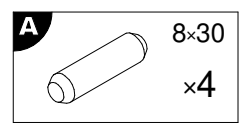

6

VARIANT 1

VARIANT 2

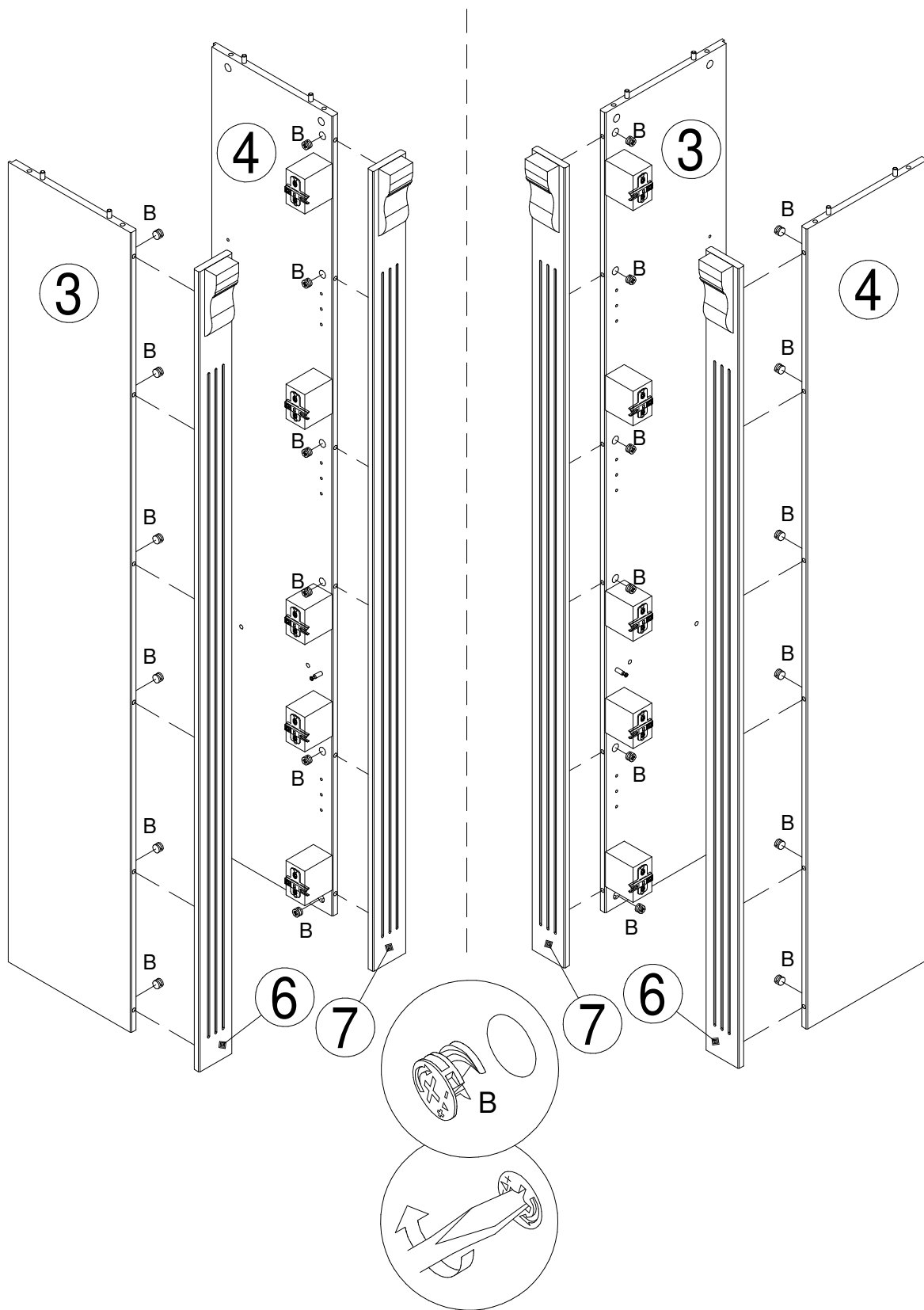

### VARIANT 1

### VARIANT 2

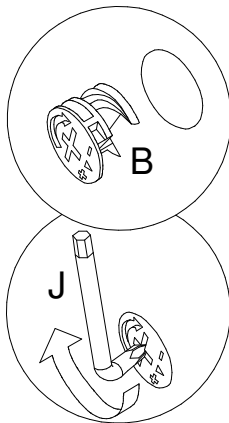
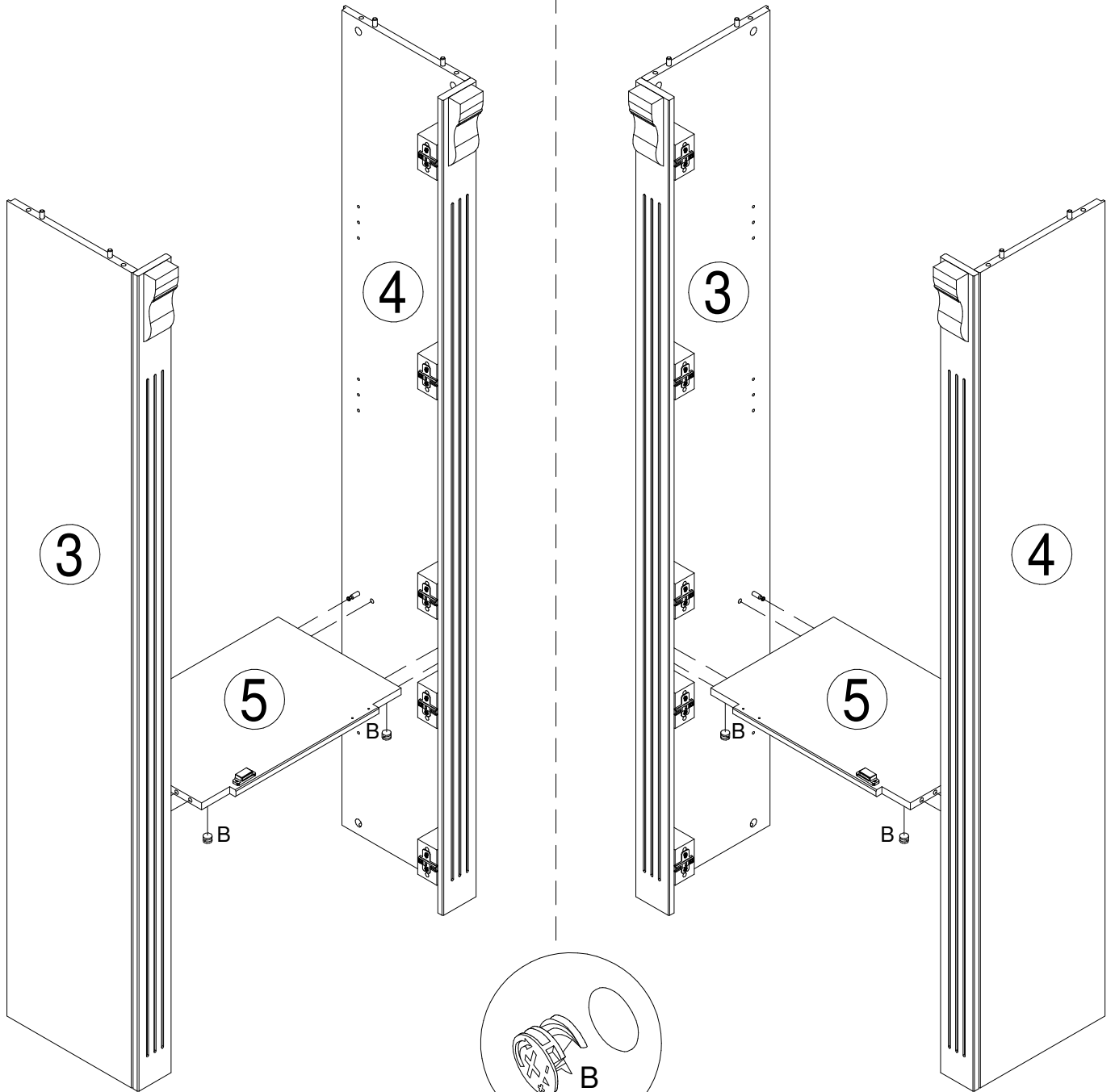





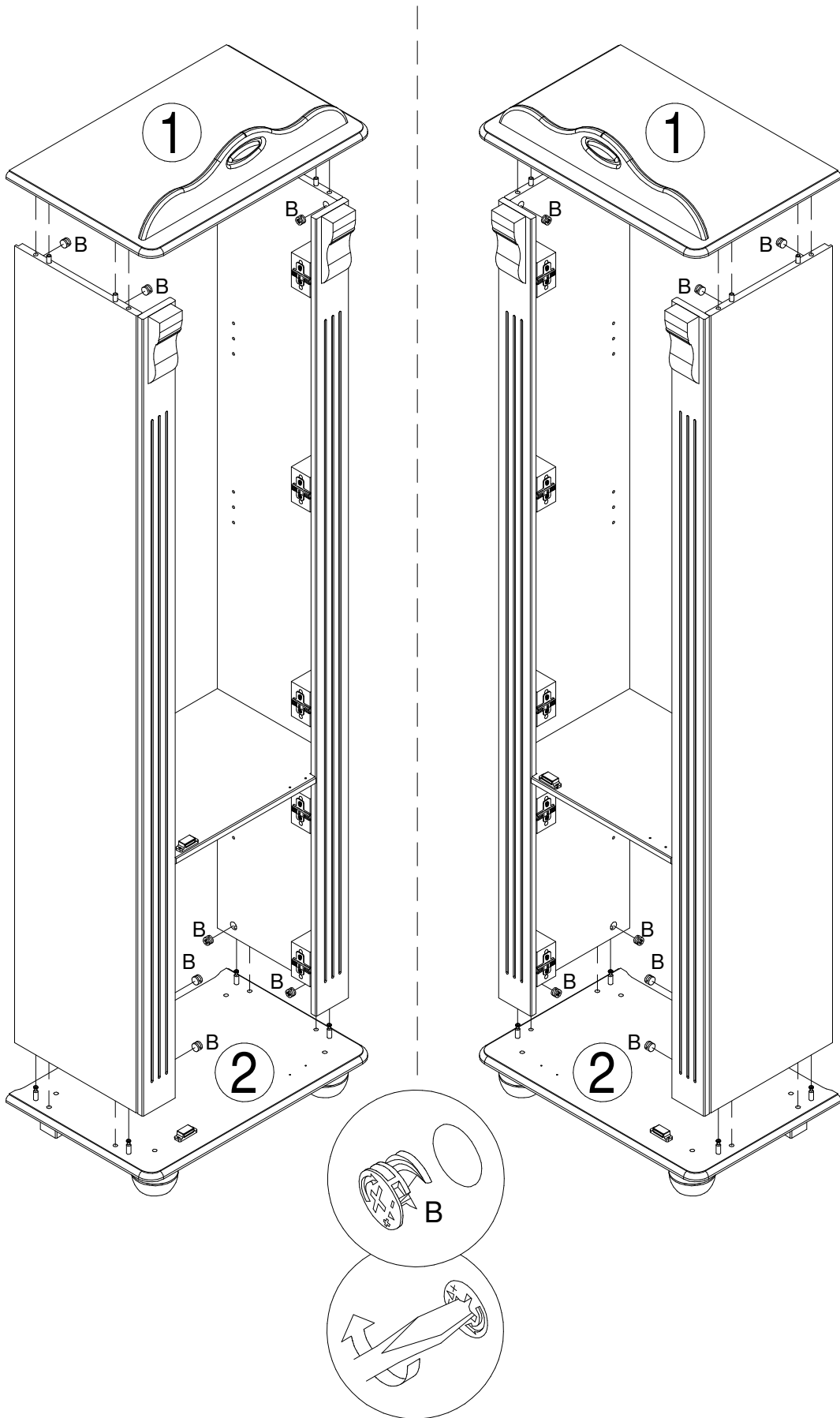

### VARIANT 1

### VARIANT 2

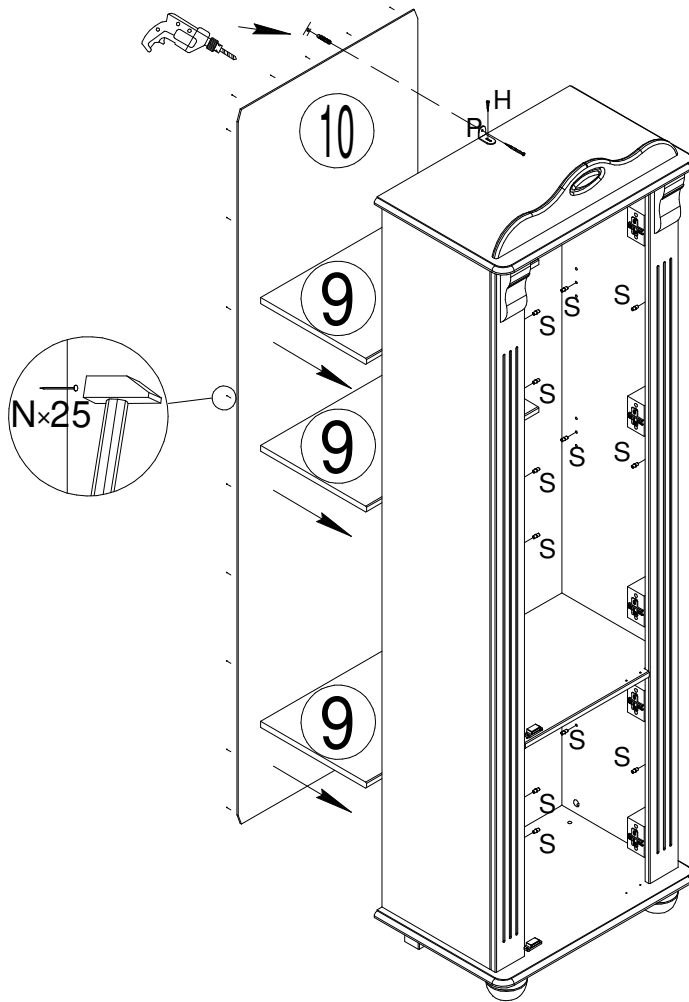

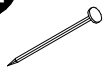
9

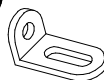

- N**  x25
- H**  3.5x15  
x1
- P**  x1
- S**  x12

VARIANT 1  
VARIANT 2





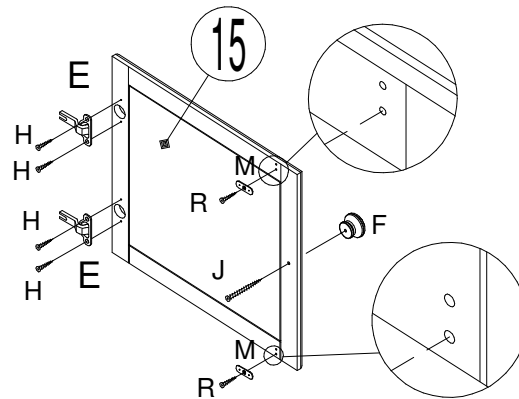
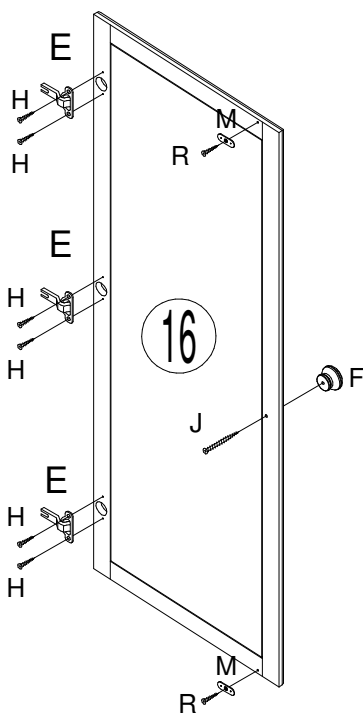

10

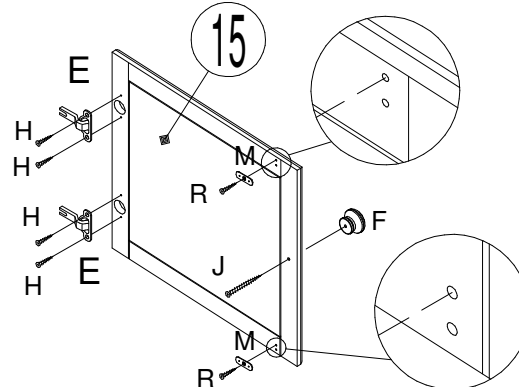
VARIANT 1

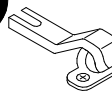

VARIANT 2

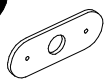

- E**  x5
- J**  3,5x35  
x2
- F**  x2
- H**  3.5x15  
x10
- M**  x4
- R**  3.0x12  
x4

VARIANT 1

VARIANT 2

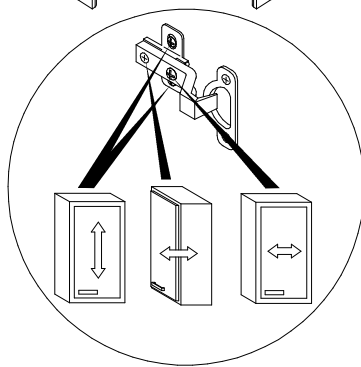
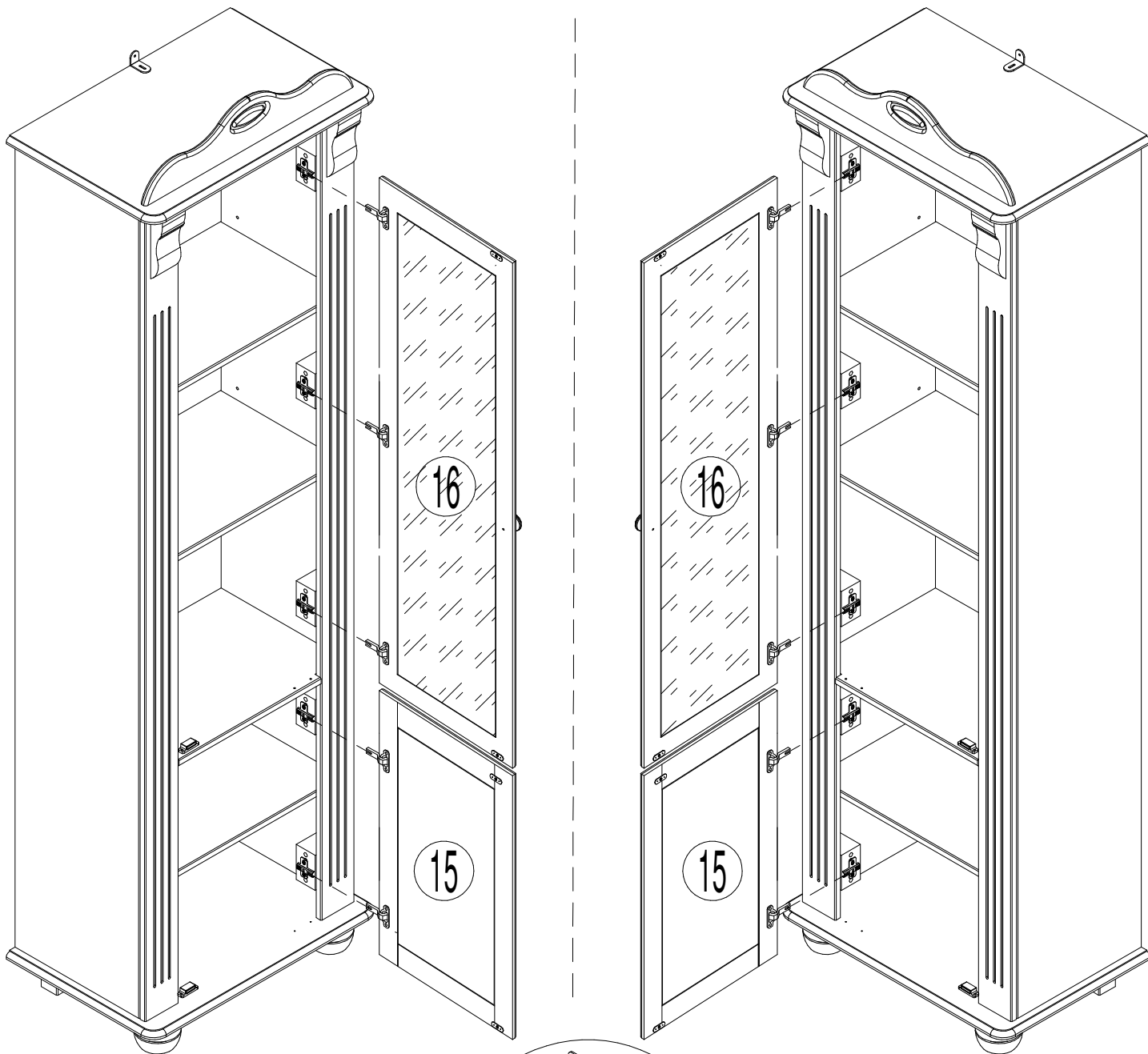



**Achtung • Attention • Attenzione  
Opgelet • Uwaga • Pozor • Figyelem  
Atenție • Dikkat • Внимание**



<b>(D)</b>	Wandbefestigung dient als Kippschutz – unbedingt anbringen! Bei einigen Wandtypen kann ein Spezialdübel erforderlich sein!
<b>(GB)</b>	The wall fastening serves to prevent tipping – be absolutely sure to mount it! For certain wall types, a special wall plug may be necessary!
<b>(FR)</b>	La fixation murale sert de protection contre le basculement – à installer impérativement ! Pour certains types de murs il faut des chevilles spéciales !
<b>(IT)</b>	Il fissaggio alla parete serve da protezione anti-ribaltamento – attaccarla assolutamente! Per alcune strutture di parete può essere necessario un tassello speciale!
<b>(NL)</b>	Bevestiging aan de muur dient als kantelbescherming – zeker en vast bevestigen! Bij enkele muurtypes is een speciale plug misschien vereist!
<b>(PL)</b>	Mocowanie do ściany jest jednocześnie zabezpieczeniem przed przewróceniem – koniecznie zamontować! Do niektórych rodzajów ścian koniecznie zastosować specjalne kołki mocujące.
<b>(CZ)</b>	Montáž na stěnu slouží jako ochrana proti převrhnutí – bezpodmienečně umístěte! U některých typů stěn může být zapotřebí speciální hmoždinka!
<b>(SK)</b>	Upevnenie na stenu slúži ako ochrana proti prevráteniu – bezpodmienečne použite! Pre niektoré druhy stien môže byť potrebná špeciálna hmoždinka!
<b>(HU)</b>	A terméket a falhoz kel rögzíténi, különben az felborulhat! Egyes faltípusoknál speciális tiplit kell használni!
<b>(RO)</b>	Sistemul de fixare la perete servește ca protecție la răsturnare – de montat obligatoriu! Pentru unele tipuri de pereți este posibil să fie necesar un diblu special!
<b>(TR)</b>	Duvardaki sabitleme, devrilmeye karşı bir emniyet tedbiridir ve mutlaka monte edilmelidir! Bazı duvar tiplerinde bunun için özel bir dübel gerekli olabilir!
<b>(RU)</b>	Обязательно установите крепление на стене во избежание опрокидывания! Для некоторых типов стен может потребоваться специальный дюбель!